

Extended Abstract

Pasadena Very-Broad-Band System and Its Use for Real-time Seismology

Hiroo Kanamori

Seismological Laboratory, California Institute of Technology
Pasadena, California 91125

As a joint project between California Institute of Technology, The University of Southern California, The United States Geological Survey, and The Incorporated Research Institutions for Seismology, a very broadband seismograph system was installed in November 1987 at the Kresge Laboratory of California Institute of Technology (Figure 1). The system consists of a 3-component Wielandt-Streckeisen seismometer, Kinematics FBA-3 accelerometer and a Quanterra 24-bit data logger with telephone dial-up capability. The system is essentially similar to the one developed by Steim(1985) and installed at the Harvard Observatory, Massachusetts. One significant difference is a 3-component strong-motion data channel which is added to obtain on-scale recordings of large regional earthquakes. The overall dynamic range is about 200 db. The response of the system is approximately flat in velocity over a period range from 0.2 to 370 sec. The sampling interval is 20 samples per second.

The dual (Streckeisen + 24-bit digitizer and FBA3 + 16-bit digitizer) system with telephone dial-up capability allows semi-real-time determination of local magnitude of large regional events.

Figure 2 shows the recordings of an $M_L=5$ earthquake in the Whittier Narrows area. The acceleration at Pasadena was about 1 cm/sec^2 , which was large enough to clip the N-S component of the very-broadband channel. The low-gain (strong motion) channel recorded this motion without clipping, and produced undistorted displacement records as shown in the figure. The peak-to-peak amplitude of the ground motion is approximately 1 mm. The saturation level of the low-gain channel is 1 g (980 cm/sec^2) so that this system can provide on-scale recordings of practically all large regional events.

Figure 3 compares four earthquakes in the Whittier Narrows area with the local magnitudes of approximately 5, 4, 3, and 1.5.

A significant difference in the wave form between different events suggests a difference in the mechanism of these events. For example the P-wave polarity of 1/19 event is opposite to that of the other events. The amplitude ratio of NS to EW components of 2/11 event is larger than that of the others.

These wave-form data combined with the results from the existing Southern California Seismic Network can be used to determine source mechanisms quickly. For the three earthquakes in the Whittier Narrows area ($M_L=3, 4, \text{ and } 5$), integration of the broadband records yielded simple displacement records from which the source time functions could be easily inferred. Figure 4 shows the displacement records rotated into the transverse(T) and the radial(R) components. The wave form of the SH wave recorded on the T component represents the moment rate function of the source (e.g. far-field source time function). A good estimate of the mechanism and the seismic moment of these events could then be obtained through inversion of the wave-form data. Here we used a very simple scheme. The basic data used are the amplitudes of the vertical component of the P wave, and the transverse and the radial components of the S wave. Since the number of unknown parameters is 4 (dip, rake, strike, seismic moment), it is not possible to determine the source parameters uniquely. We look for the solution that satisfies the observed amplitude data in the closest neighborhood of the first approximation obtained from the local P-wave first-motion data. Figure 5 shows the comparison between the observed and synthetic wave forms computed for the first approximation and the final solution. The first-motion mechanisms were provided by Lucy Jones (personal communication, 1988). If we have two or more stations, the non-uniqueness can be removed, and the method allows rapid determinations of the source parameters of regional events.

Since the broadband data provide undistorted source time functions, they allow quick and intuitive source mechanism determinations.

Figure Captions

Fig. 1

A simplified block diagram of the Kresge VBB system.

Fig. 2

Wave forms of an $M_L=5$ earthquake in the Whittier Narrows area, southern California. Upper left: Wood-Anderson records

simulated from the broadband (Streckeisen) records. Note the clipping on the NS component. Lower left: Wood-Anderson records obtained from the low-gain (strong motion) channel. The ground motion is recorded without clipping. Lower right: Ground motion displacement obtained from the low-gain (strong motion) record.

Fig. 3

Wood-Anderson records of four earthquakes in the Whittier Narrows area with local magnitudes ranging from 1.5 to 5. Note the difference in the amplitude scale for different events.

Fig. 4

Rotated seismograms of ground-motion displacement of the three earthquakes in the Whittier Narrows area. Note the difference in the pulse width and amplitude. The S waves on the vertical and radial components exhibit the effects of interaction between the free surface and the incoming SV waves.

Fig. 5

Comparison between the observed (top) and synthetic records (middle and lower) for the three earthquakes in the Whittier Narrows area. The synthetics shown in the middle are computed for the mechanism determined from P-wave first-motion data (Lucy Jones, personal communication, 1988). The synthetics at the bottom are obtained by inversion of P and S wave amplitudes. M_w is calculated from the seismic moment.

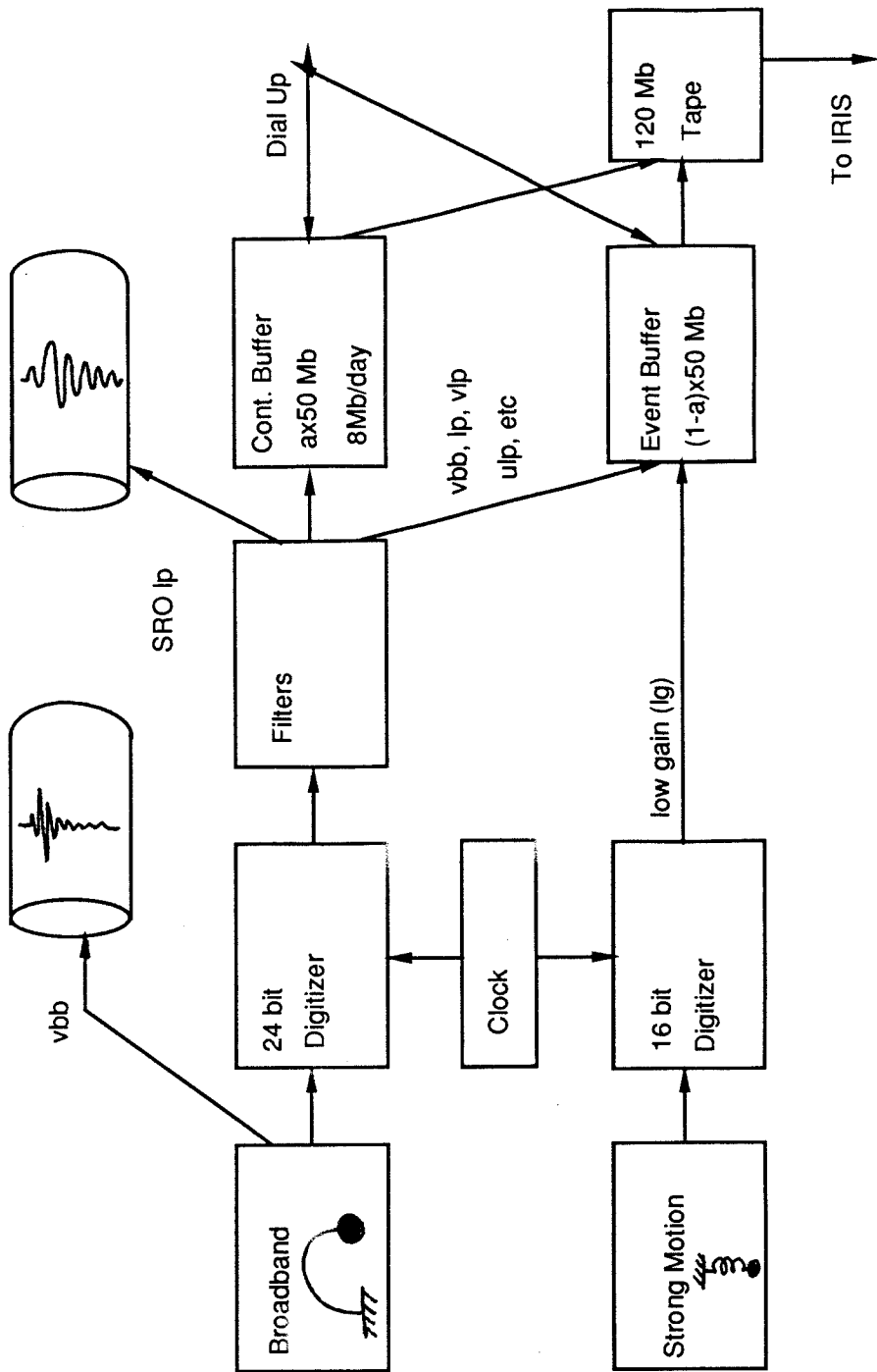

Kresge Very-Broadband System

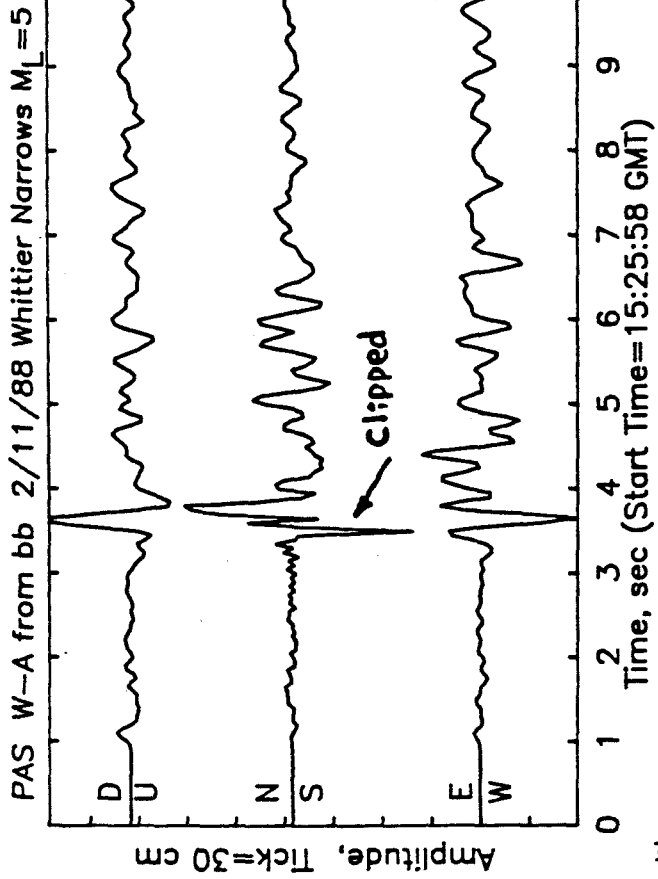

139

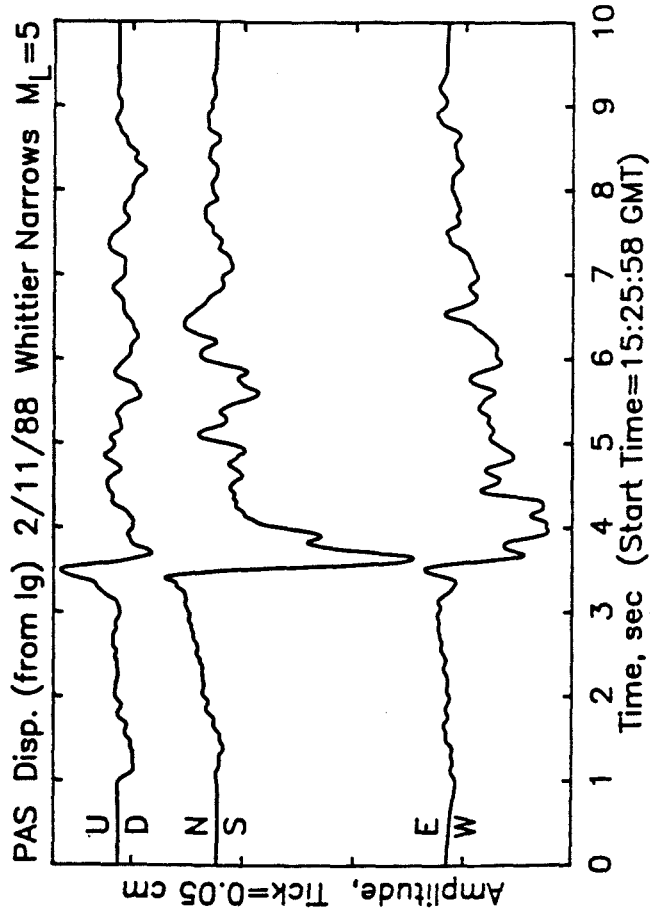
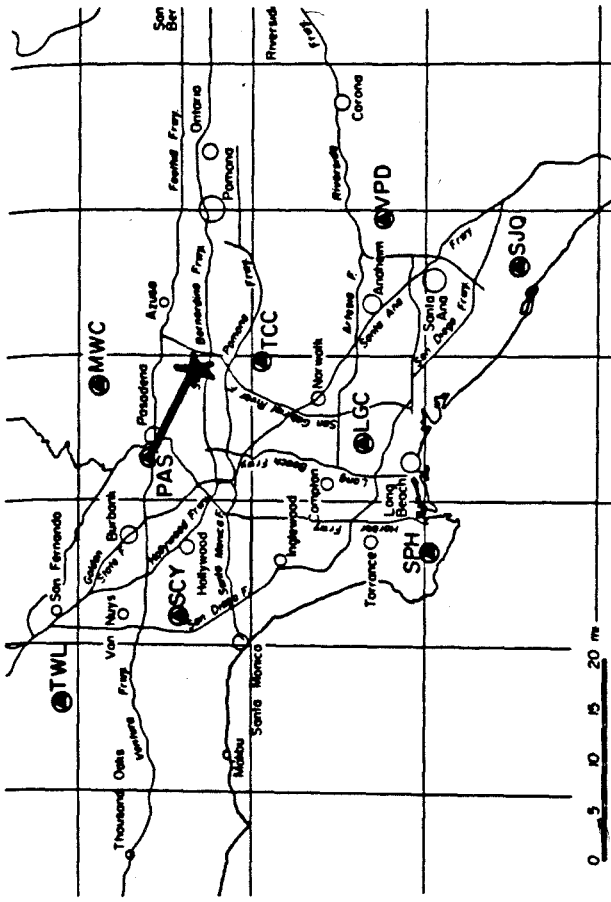
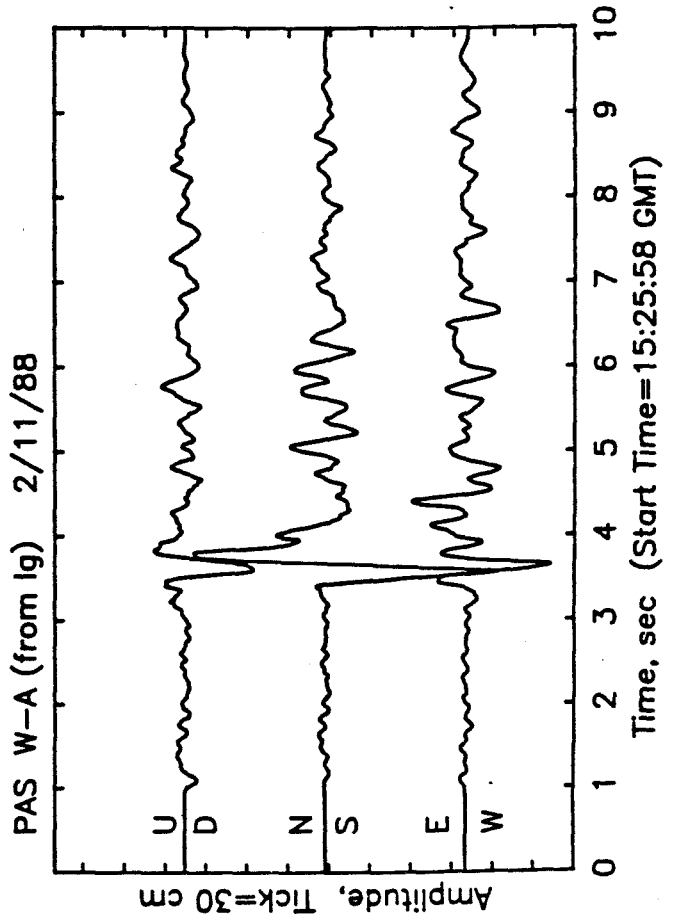

Fig. 2

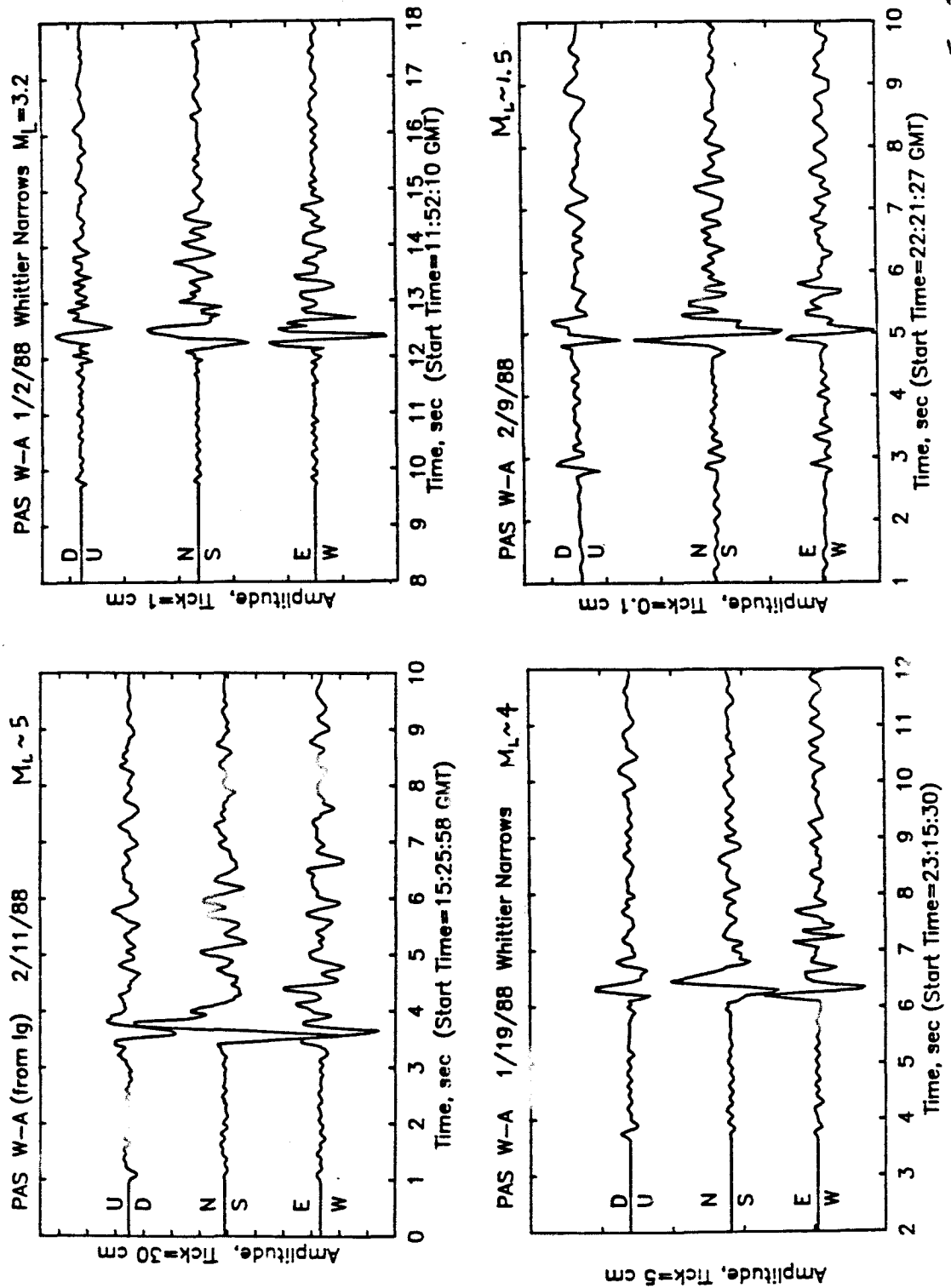
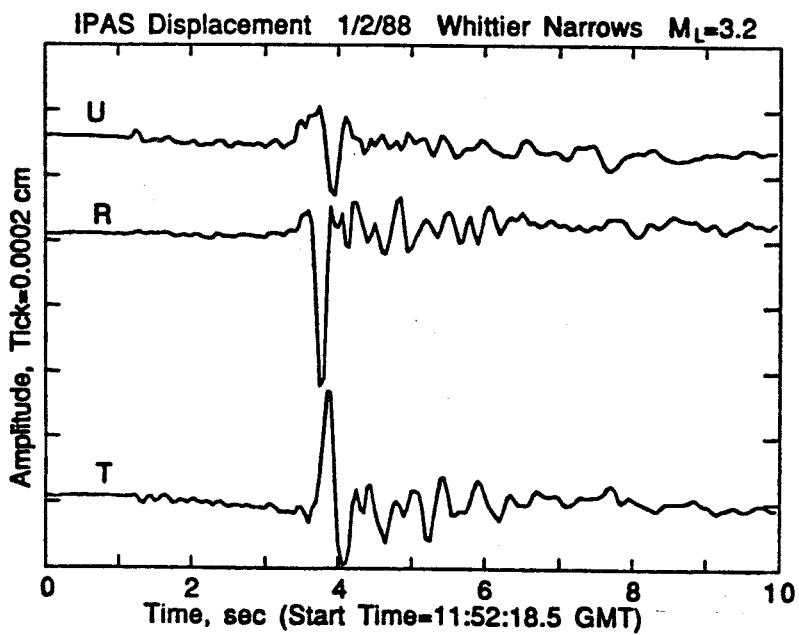
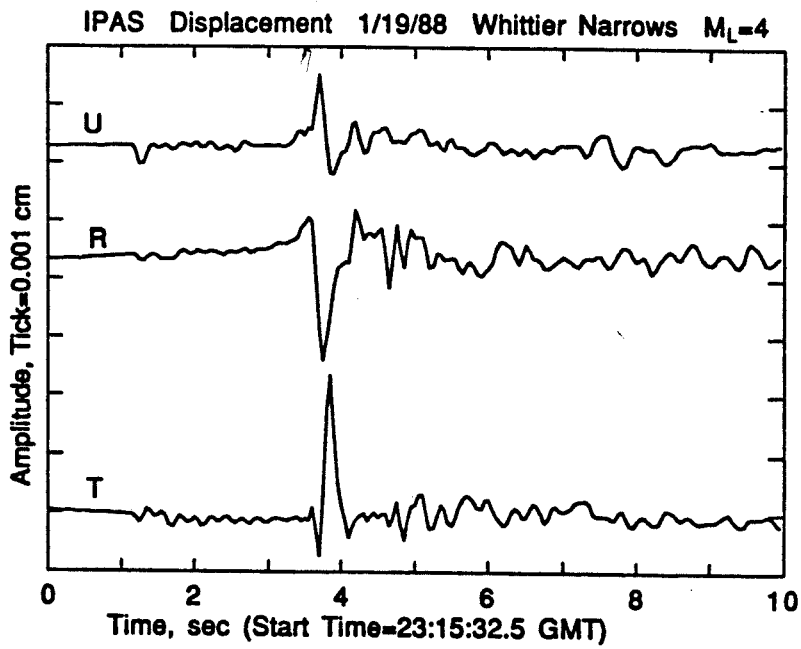
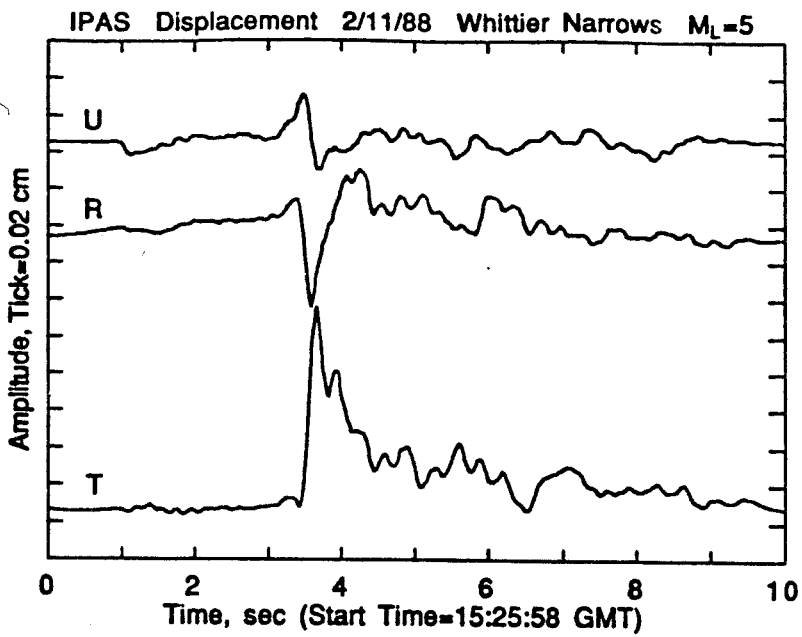
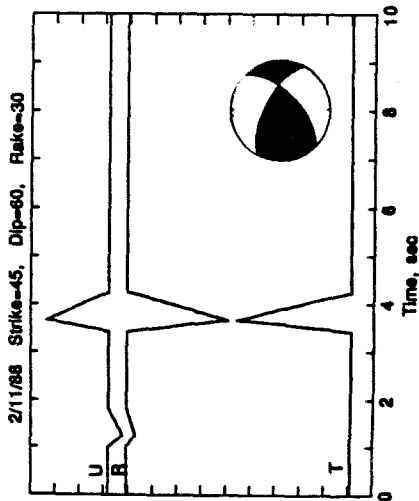
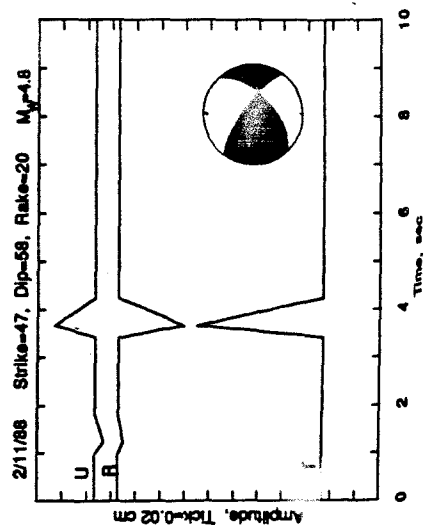
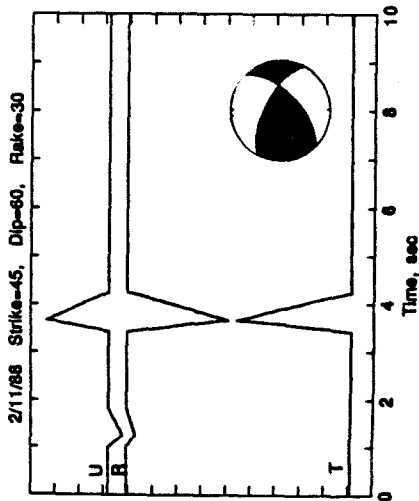
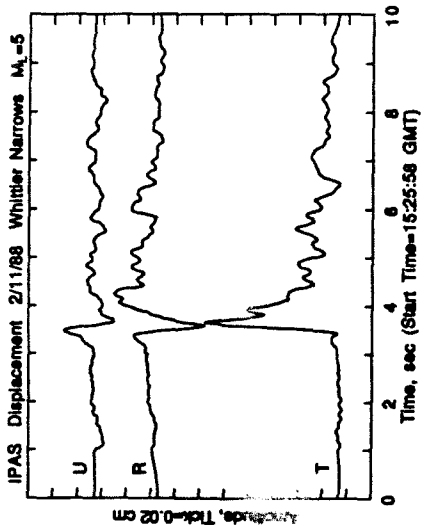

Fig. 3



a



b

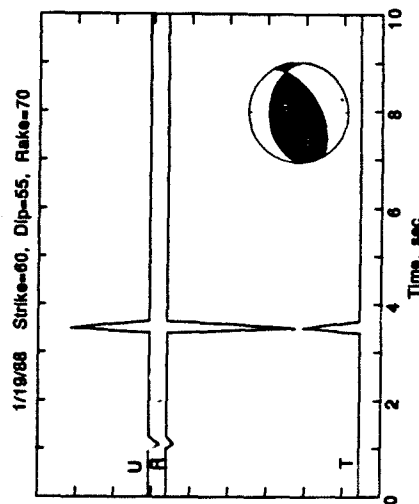
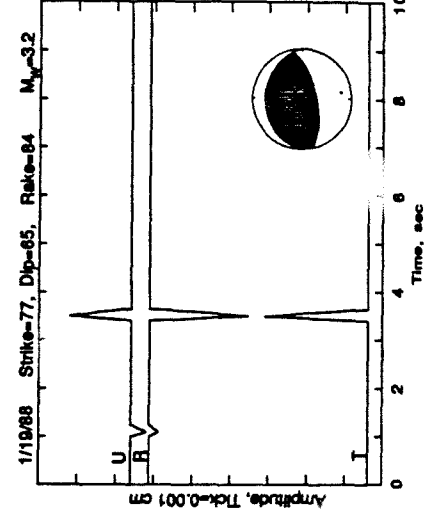
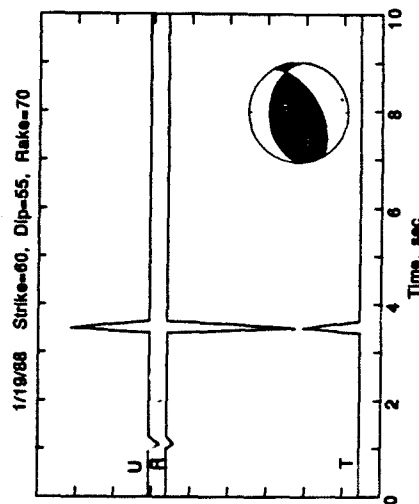
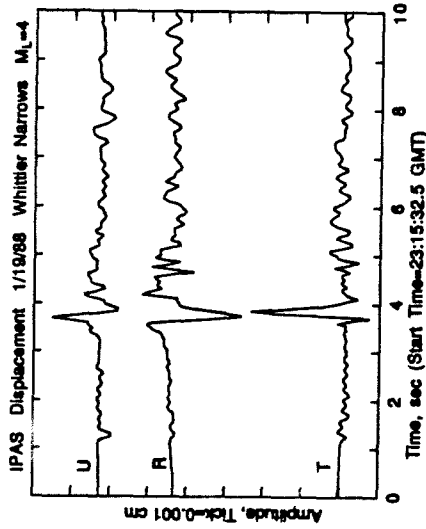

c

